

PAR 350 M

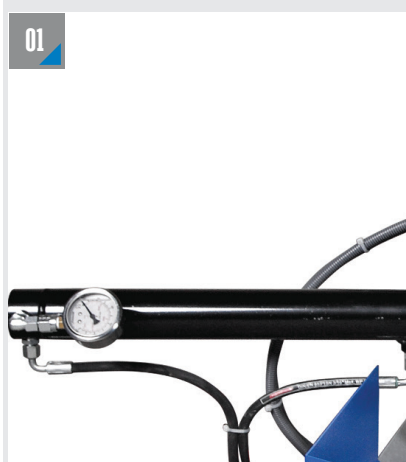

TAM OTOMATİK AÇILI TESTERE TEZGAHI FULL AUTOMATIC MITER BANDSAW MACHINE



MALZEME SIKMA SİSTEMİ
MATERIAL CLAMPING SYSTEM



MALZEME SÜRME SİSTEMİ
MATERIAL FEEDING SYSTEM

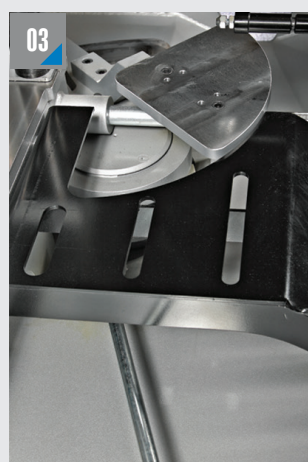

AÇI KİLİTLEME
MITER FIXING

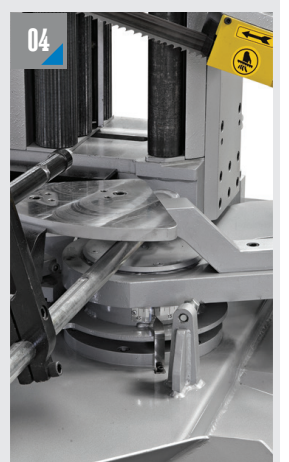

DÖNER GÖBEK SİSTEMİ
MITER CUTTING

ÖLÇÜLER DIMENSIONS

MAFSALLI MODELLER PIVOT TYPES

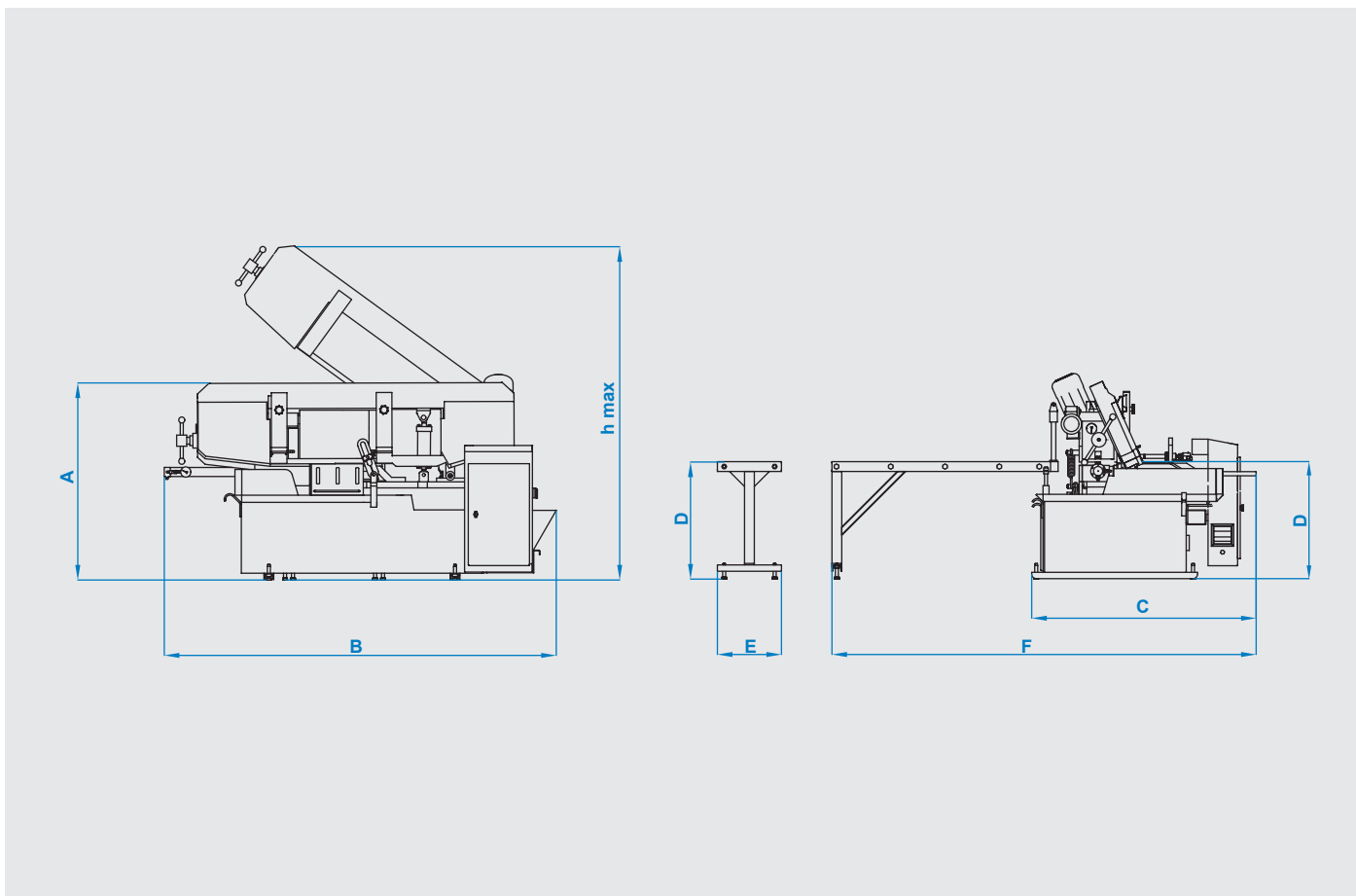

TEKNİK ÖZELLİKLER / TECHNICAL FEATURES

A	1370 mm 53.94 inch	B	2600 mm 102.36 inch	C	1480 mm 58.27 inch	D	775 mm 30.51 inch	E	525 mm 20.67 inch	F	2800 mm 110.24 inch	hmax	2150 mm 84.65 inch
---	-----------------------	---	------------------------	---	-----------------------	---	----------------------	---	----------------------	---	------------------------	------	-----------------------

Yarı Otomatik Semi Automatic	Şerit Ölçüsü Blade Dimension 34 x 1.1 x 4555 mm 1 1/4 x 0.042 x 179.3 inch	Şerit Motoru Blade Motor 4 kW - 1500 d/d 5.36 hp - 1500 rpm	Sürücü Motor Feeding Motor 0.25 kW - 1500 d/d 0.33 hp - 1500 rpm
Hidrolik Motor Hydraulic Pump Motor 0.75 kW - 1400 d/dk 1 hp - 1500 rpm	Soğutucu Motor Cooling Liquid Motor 0.12 kW - 3000 d/dk 0.16 hp - 3000 rpm	Voltaj Voltage 400 V 400 V	Maksimum Güç Maximum Power 5.12 kW 6.86 hp
Kesme Hızı Cutting Speed 15 m/dk - 115 m/dk 100 m/dk - 230 ft/min	Ağırlık Weight 1150 kg 2335 lbs	Malzeme Sıkma Sistemi Material Clamping System Hidrolik Hydraulic	Şerit Germe Sistemi Blade Tensioning System Hidromekanik Hydramechanic

Kesim Kapasitesi Cutting Capacity 350 mm 13.78 inch	Kesim Kapasitesi Cutting Capacity 410 mm 16.14 inch	90°	60°	45°	30°	0°	30°	45°	60°