

# PAR 350 U PLC

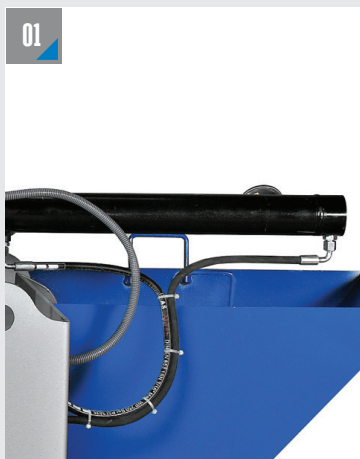

## TAM OTOMATİK PLC KONTROLLÜ TESTERE TEZGAHI FULL AUTOMATIC PLC CONTROL BANDSAW MACHINE



**MALZEME SIKMA SİSTEMİ**  
MATERIAL CLAMPING SYSTEM



**MALZEME SÜRME SİSTEMİ**  
MATERIAL FEEDING SYSTEM



**KUMANDA PANELİ**  
CONTROL PANEL



**DAYAMASIZ HASSAS KESİM**  
ACCURATE CUTTING

## ÖLÇÜLER DIMENSIONS

## MAFSALLI MODELLER PIVOT TYPES

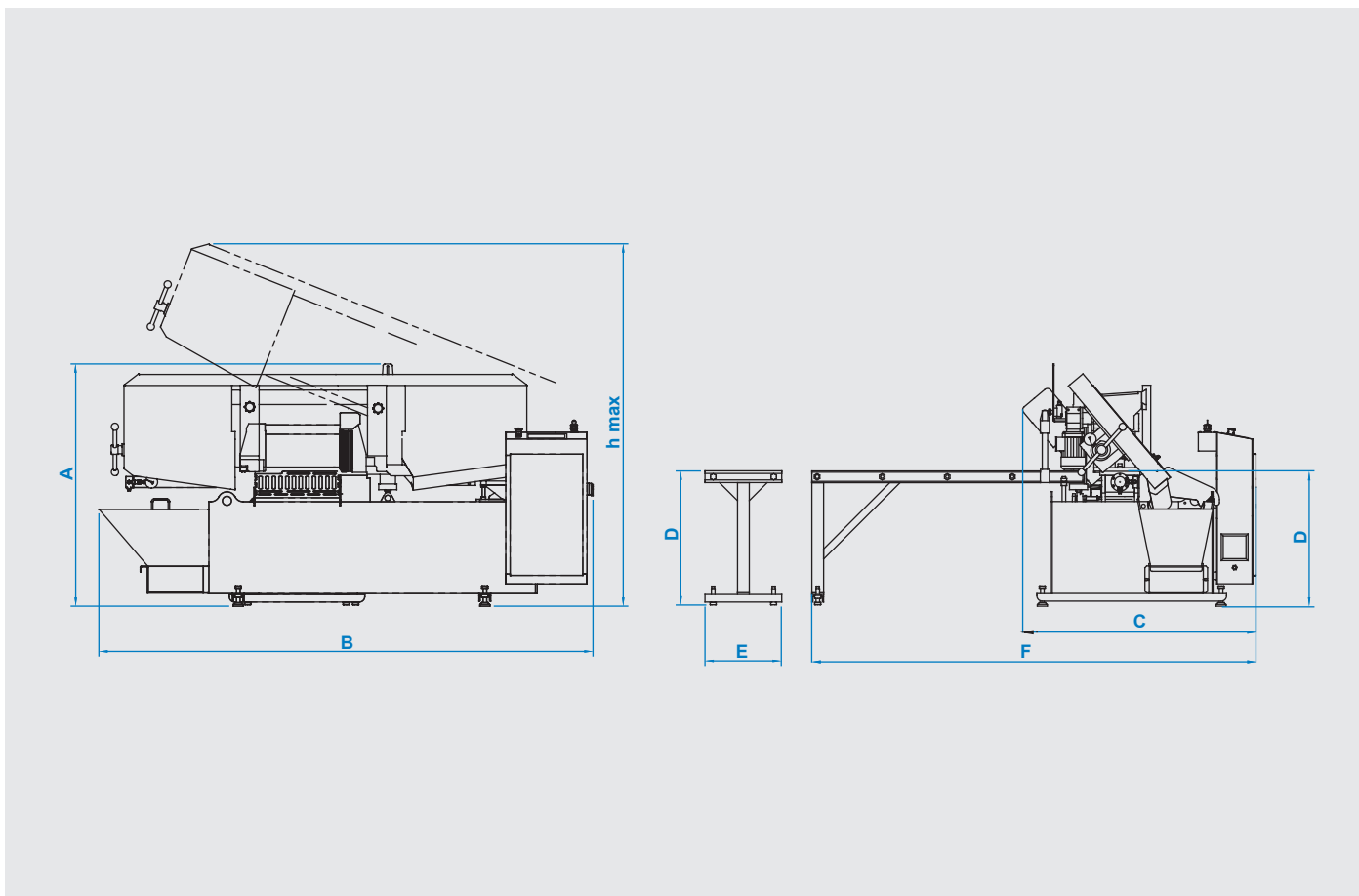

## TEKNİK ÖZELLİKLER / TECHNICAL FEATURES

A	1555 mm 61.22 inch	B	1670 mm 65.75 inch	C	1185 mm 46.65 inch	D	400 mm 15.75 inch	E	695 mm 27.36 inch	F	455 mm 17.91 inch	hmax	2010 mm 79.13 inch
---	-----------------------	---	-----------------------	---	-----------------------	---	----------------------	---	----------------------	---	----------------------	------	-----------------------

<p><b>FLC</b> Otomatik Automatic</p>	<p>Şerit Ölçüsü Blade Dimension 41 x 1.3 x 4635 mm 1 1/2 x 0.050 x 182.4 inch</p>	<p>Şerit Motoru Blade Motor 4 kW - 1500 d/d 5.36 hp - 1500 rpm</p>	<p>Sürücü Motor Feeding Motor 0.37 kW - 1000 d/d 0.49 hp - 1000 rpm</p>
<p>Hidrolik Motor Hydraulic Pump Motor 0.75 kW - 1400 d/dk 1 hp - 1400 rpm</p>	<p>Soğutucu Motor Cooling Liquid Motor 0.12 kW - 3000 d/dk 0.16 hp - 3000 rpm</p>	<p>Voltaj Voltage 400 V 400 V</p>	<p>Maksimum Güç Maximum Power 5.24 kW 7 hp</p>
<p>Kesme Hızı Cutting Speed 15 m/dk - 49 m/dk 100 m/dk - 328 ft/min</p>	<p>Ağırlık Weight 1200 kg 2645 lbs</p>	<p>Malzeme Sıkma Sistemi Material Clamping System Hidrolik Hydraulic</p>	<p>Şerit Germe Sistemi Blade Tensioning System Hidromekanik Hydramechanic</p>

<p>90°</p>	<p>mm inch</p>	<p>60°</p>	<p>45°</p>	<p>30°</p>	<p>0°</p>	<p>90°</p>	<p>45°</p>	<p>60°</p>
<p>Kesim Kapasitesi Cutting Capacity</p> <p>350 mm 13.78 inch</p>	<p>Kesim Kapasitesi Cutting Capacity</p> <p>400 mm 15.75 inch</p>				<p>350 mm 13.78 inch</p> <p>350 x 350 mm 13.78 x 13.78 inch</p> <p>200 x 400 mm 7.87 x 15.75 inch</p>			